

SUCTION LINE Typical installation shows how pipe acts as a housing around filter element. Standpipe does not entirely enclose the TU-series element: it need only extend to below minimum fluid level of the tank. A vacuum gage may be mounted just ahead of pump to indicate differential pressure across the filter.

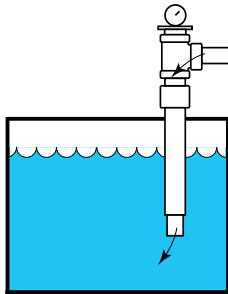

RETURN LINE Typical installation shows that piping set-up is similar to suction line installation: The only difference is that the TD-series element is used, to handle flow "down" rather than "up".



PIPE UP LOW-COST FILTERS WITH TEE-EZY, AND SAVE UP TO 60%

That's right! With your piping our Tee-Ezy kit, you'll have a true filtering system (down to 3 micron) for slightly more than you're now paying for a common sump strainer and the same amount of pipe, fittings and labor, plus:

- You can clean and replace the filtering element without draining the tank or taking apart piping.
- You can monitor filter dirt build-up by adding a dirt indicator.
- Optional bypass valves are built in to product the system from a dirt-clogged filter.
- You can filter suction or return lines.

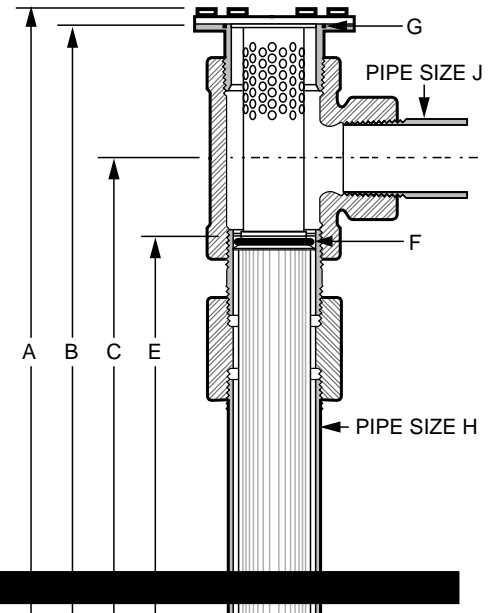

DIMENSIONS

FILTER SIZE	ELEMENT PORE SIZE	A OVERALL LENGTH*	B ELEMNT	C LENGTH*	D END CAP O.D.	E MEDIA LENGTH	F O-RING SPECS: DASH NO. / X-SECTION	G O-RING SPECS: X-SECTION	H	J
TS-12	ALLL	19-1/4	18-3/4	16	1.385	14	220/.139	137/.103	1-1/2	1
TS-18	60,100,200 ALL OTHERS	19-7/8 19-7/8	19-3/8 19-3/8	16-3/8 16-3/4	1.835 1.835	14	225/.139	144/.103	2	1-1/4
TS-45	60,100,200 ALL OTHERS	21-1/4 21-1/4	20-3/4 20-3/4	16-3/4 16-3/4	2.234 2.864	14	233/.139	153/.103	3	2
TS-100	60,100,200 ALL OTHERS	23-3/4 21-1/4	23-1/4 20-3/4	18-3/8 16-3/4	2.862 2.864	14	241/.139	247/.139	4	3

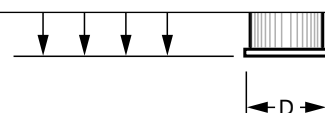

TEE-EZY™ FILTERS

INSTALLATION

When laying out assembly:

1. Be sure there's clearance to remove the element assembly from the piped housing. For size 12, 18 and 45, you'll need 22 inches, and for size 100, 25 inches.

2. In suction-line applications, pipe flow comes in at the end, or from all sides (Fig. 1 and 2). Don't let flow impinge against one side only (Fig. 3). The more exposed an element, the longer it will serve without clogging.

3. Use standard schedule 40 pipe and 125-psi pressure service fittings.

The important O-ring seal:

To prevent fluid from bypassing the element, an O-ring is used to seal the space between the cartridge and the pipe housing. Because the I.D. of schedule 40 pipe may vary beyond the sealing range of the O-ring, a properly sized and machined nipple can be ordered. It is threaded into the bottom of the tee.

If you don't wish to use the nipple, use any schedule 40 pipe that you can seal with the O-ring (see O-ring specs), and give it the proper internal chamfer, to compress the O-ring. See Fig. 4. (Always lubricate O-ring before inserting cartridge.)

4. If you use the pre-machined nipple, you must file an entry bevel of about 15° by 1/8 in. on the I.D. of the standpipe. The I.D. of the pipe must be such that the O-ring seals against it.

5. To install the clean-out port in your tee fitting, a simple wrench adapter like that shown is easily made up.



1.



2.



3.



4.



5.

PERFORMANCE

TEE-EZY Size Designation	Filter Element Pore Size	GPM @ 1 P.S.I.D.*
TS-12	60, 100 or 200 Mesh (74 μm)	12
TS-18	60, 100 or 200 Mesh (74 μm)	18
	15 or 40 Micron	14.8
	20 Micron	9.7
TS-45	60, 100 or 200 Mesh (74 μm)	45
	40 Micron	39
	20 Micron	25
	15 Micron	38
	10 Micron	5
TS-100	60, 100 or 200 Mesh (74 μm)	100
	40 Micron	74
	20 Micron	62
	15 Micron	71
	10 Micron	12
	3 Micron	8

* Pounds per square inch differential pressure, using 150 SSU viscosity oil. All figures were developed using clean elements and standpipes that extended beyond end of element cartridges. Recommended piping, that exposes end of cartridge (as shown in drawings), would provide higher flows at same pressure differentials.

HOW TO ORDER

First, build an ordering code for the clean-out port and cover, as in this example:

TS - 18 - N - F3
Style - Size - Nipple - Viton O-Ring

STYLE	SIZE	NIPPLE	O-RING
TS	12 18 45 100	N (nipple with machined I.D. for good O-Ring seal)	No Symbol = Buna N F3 = Viton

Second, build an ordering code for the replacement element assembly, as in this example:

TU - 18 - 74 - RV3 - F3
Style - Size - Element - Valve - Viton O-Ring

STYLE	SIZE	ELEMENT GRADE (Micron Size)	BYPASS	O-RING
TU (Flow up for suction line)	12	238 micron 149 micron 74 micron	RV3 (3-psi)	No Symbol = Buna-N
	18	149 micron 74 micron	RV5 (5-psi)	
TD (Flow down for return line)	45	40 micron, synthetic	RV15 (15-psi)	F3 = Viton
	100	20 micron, cellulose 15 micron, double syn. 10 micron, cellulose	RV30 (30-psi)	
	45 100	3G 3 micron, micro glass		